

## DUAL USE POWER SUPPLY DEVELOPMENT

Alan C. Kolb and Bryan E. Strickland  
Maxwell Laboratories, Inc.  
8888 Balboa Avenue  
San Diego, CA 92123  
(619) 576-7500 and 576-7709

### Abstract

Size, weight, efficiency and reliability define space power systems. Ten years ago NASA re-emphasized that missions such as Space Station needed cost effective critical technologies, one being power conversion. Thus, NASA began to emphasize "dual-use" technology through its Center for Commercial Development of Space (mid 1980s). This CCDS program funded research and development efforts needed for future space missions as well as terrestrial applications for commercial markets. Maxwell and Auburn University (Space Power Institute) jointly developed reliable power systems for manned space projects as well as commercial applications of high power, high voltage switchmode power supplies. These serve the medical, scientific and industrial markets (lasers, accelerators and intense light sources). These applications required improvements in power density, efficiency, regulation, reliability and cost effectiveness to be successful. One of NASA's first programs at Auburn and Maxwell was a high frequency, series resonant power converter optimized for commercial applications. It also meets the needs of space missions (additional space flight qualification is needed). This power converter topology demonstrates dual-use technology for power density, power-to-weight, regulation, reliability and cost effectiveness. All goals were exceeded for both space and terrestrial applications. This was the first product of NASA's CCDS program producing a family of high voltage capacitor charging power supplies. Maxwell's CCDS capacitor power supplies are achieving greater acceptance demonstrating the value of the CCDS program.

### INTRODUCTION

The CCDS power supplies, developed in conjunction with the Center for Commercial Development of Space (CCDS) Office at the Auburn University, Space Power Institute provide a compact, reliable, efficient source of capacitor charging with output powers from 2 to 10 kW and output voltage from 1 to 50 kV (Cathell et al. 1990, 1991, 1992, 1993). The design of the CCDS power supplies is based on a high frequency series resonant power conversion topology combined with a patented control topology for superior regulation. By applying the reliability criteria of rigorous space applications to a modular design, a commercially viable product with a theoretically predicted MTBF of greater than 24,000 hours of high voltage operating time at full power and full voltage was achieved. The demonstrated results of the philosophy(s) behind the CCDS power supplies have driven the capacitor charging marketplace to significantly higher standards of performance, cost effectiveness and customer satisfaction.

The CCDS power supply family, consisting of over 1000 specification configurations, is now a standard catalog item with competitive price and delivery. Hundreds have been sold to national laboratories and corporations making OEM equipment for scientific, medical and industrial applications. Using the experience gained with the CCDS power supplies, Maxwell has independently developed two other power supply families: constant voltage, auto-crossover power supplies and current regulated, arclamp or simmer power supplies. Further penetration of the high power, high voltage power supply market in the United States, Asia, Far East and Europe is well under way. A few prototype CCDS power supplies have been delivered to Japanese laser fabricators and current efforts address further penetration of the Japanese market.

### Maxwell Overview Information

Maxwell Laboratories Inc., a public company, was founded in 1965 to conduct research and develop products based on application of electromagnetism and other related scientific disciplines. The company was named after James Clerk Maxwell (1831-1879), a Scottish physicist who is considered the father of electromagnetic field theory. The founding group believed they could build a better capacitor, and over the next three decades led the industry in energy density and reliability. The company started with an attitude of personal pride and craftsmanship and has grown into a profitable, high technology manufacturing and services company with a diversity of products ranging from a \$20 million turnkey x-ray synchrotron facility to electronic subassemblies such as industrial computers and power supplies to standard pulsed power components such as capacitors, resistors, and fuses. Service products include

computer simulation studies, analysis of the effects of nuclear and conventional weapons, and analytical chemistry testing of samples for regulatory environmental purposes. Today, with its headquarters located in San Diego, Maxwell has grown to over 600 people organized into five divisions and one subsidiary.

Maxwell offers the world's most extensive capabilities in pulsed power technologies used to manufacture systems and components that create and control intense bursts of electrical energy. Its broad line of energy-storage capacitors has established Maxwell as the leading manufacturer of high-energy-density capacitors where Maxwell is the leading manufacturer of medical defibrillator capacitors.

### **A NASA Requirement at the Start**

From the start of the CCDS program, Maxwell and Auburn recognized the need for an efficient and lightweight power supply to support a wide variety of space and terrestrial applications requiring sophisticated "tools" such as lasers for material processing, heating, cutting, welding and drilling. The high voltage power supply would have to be highly reliable for long term, space based missions and uptime critical, commercial applications where the "tool," such as the laser, may be the difference between life and death in space, or millions of dollars which may be lost due to unplanned downtime in a production line. This activity combined with Maxwell's high voltage pulsed capacitor market leadership produced a power supply design which was not only reliable and compact, but also energy efficient for charging capacitors with very high levels of repeatability.

Many Maxwell customers who buy Maxwell capacitors for terrestrial applications voiced a need for an efficient high voltage capacitor charging power supply. In response, Maxwell proceeded with the development of commercial power supplies which would provide increased efficiency, regulation, and power density for pulsed lasers, RF sources, and other industrial applications.

### **A Down-to-Earth Product Line**

Maxwell's commercial line of capacitor charging, high voltage power supplies carry the CCDS model designation and provide an efficient and reliable source of power for flashlamps, capacitors, and capacitor banks. The various models have average output power ratings from 2 to 8 kJ/s with high voltage outputs from 10 to 50 kV. All units feature a high frequency switch-mode power converter topology, an EMI filter, an inrush current limit circuit along with high temperature, overcurrent and overvoltage protection.

### **A Power Supply for High Energy, Pulsed Gas Lasers**

The performance characteristics of the power supply in a high power, pulsed excimer, CO<sub>2</sub> TEA or metal-vapor laser dominate the optical output beam. In these types of lasers, the power supply charges capacitors which are then discharged into the gas lasing medium. During the charging cycle, the power supply sees a capacitor which, at the start, looks like low impedance (short circuit), and as the charge builds up, changes to a high impedance (open circuit). This dynamic load on the power supply requires little energy output at the start of the charging cycle. The output energy rises as the capacitor charge builds up, until the power supply reaches its peak output when the capacitor is fully charged. The ability of a capacitor charging power supply to charge the capacitors to the same level, repetitively, dictates the pulse-to-pulse intensity variation exhibited in the laser beam. The power output rate at which the power supply charges a capacitor defines the duration of the charging cycle, the maximum rep-rate and, ultimately, the rated power output of the laser. The ability of a power supply to meet the laser's power demands during rapid recharge cycle, without overheating, is a large measure of a power supply's quality.

## **THE CCDS POWER SUPPLY TECHNICAL DESCRIPTION**

Designers of today's rep-rate lasers, medical accelerators, power modulators and other rep-rate capacitor discharge circuits are faced with decisions of how to best charge the capacitor in their system. The designer has to weigh the trade-offs of the practical capacitor charging approaches and choose the technique which best suits his overall system and programmatic requirements.

### **Charging Schemes**

There are three common techniques of capacitor charging; resistive charging, one-cycle resonant charging with or without deQing, and high frequency constant current charging. Each technique is arguably the most practical approach for particular applications.

**Resistive Charging.** For very low average power applications where circuit simplicity is the dominating design factor, and where size, regulation, and efficiency are not critical issues, resistive charging is the appropriate choice for the designer. Resistive charging is the simplest capacitor charging technique; however, it is the least efficient (50%), has comparatively poor regulation, and is not the most compact.

**One-cycle Resonant Charging.** For medium and high power applications, one-cycle resonant charging is a practical technique. One-cycle resonant charging without deQing is also a relatively simple circuit topology; however, the achievable regulation is equal to the ac line regulation. In addition to the basic transformer rectifier, the system must have an additional energy storage capacitor, inductor, and switch. The switch can be a simple diode or a unidirectional closing switch like a thyatron or SCR. One-cycle resonant charging with deQing can provide capacitor charging with regulation of 0.1%. While one-cycle resonant charging can result in well-regulated, relatively efficient capacitor charging, it utilizes bulky 60 Hz technology and requires the storage of energy in the circuit.

**High Frequency Constant Current Charging.** For medium and high power systems where minimum volume, high efficiency, and regulation are critical design criteria, high frequency constant current charging may be the most practical capacitor charging technique. For power levels below 1.5 kJ/s and voltages below 10 kV, a flyback topology is a very practical means of capacitor charging. Flyback converters are typically limited in the maximum practical operating power due to the inherent requirement for the high frequency switching device to open during maximum current flow. Thus the switches are subjected to switching and conduction losses. In addition, there is also a practical maximum output voltage for flyback converters since the voltage stress on the output diode is approximately 3 times  $V_{out}$ .

A series resonant converter is ideally suited for capacitor charging applications since it reflects a high source impedance to the output; consequently, this topology is inherently short circuit proof. The output characteristics also result in a constant current (linear) charging profile, provided the transformer turns ratio is chosen properly. Although a relatively complicated circuit, the series resonant high frequency converter provides the most compact, efficient capacitor charging technique at kilowatt power levels.

### Series Resonant Converter

For high power applications, a series resonant H-bridge inverter topology is the most practical approach. An H-bridge series resonant inverter is shown in Figure 1. For converters operating in the 50 kHz range, the switches used in the inverter are typically parallel banks of MOSFETs or IGBTs. The characteristics of these devices provide high voltage, high current capability and easy device paralleling and control. When used as switches in a series

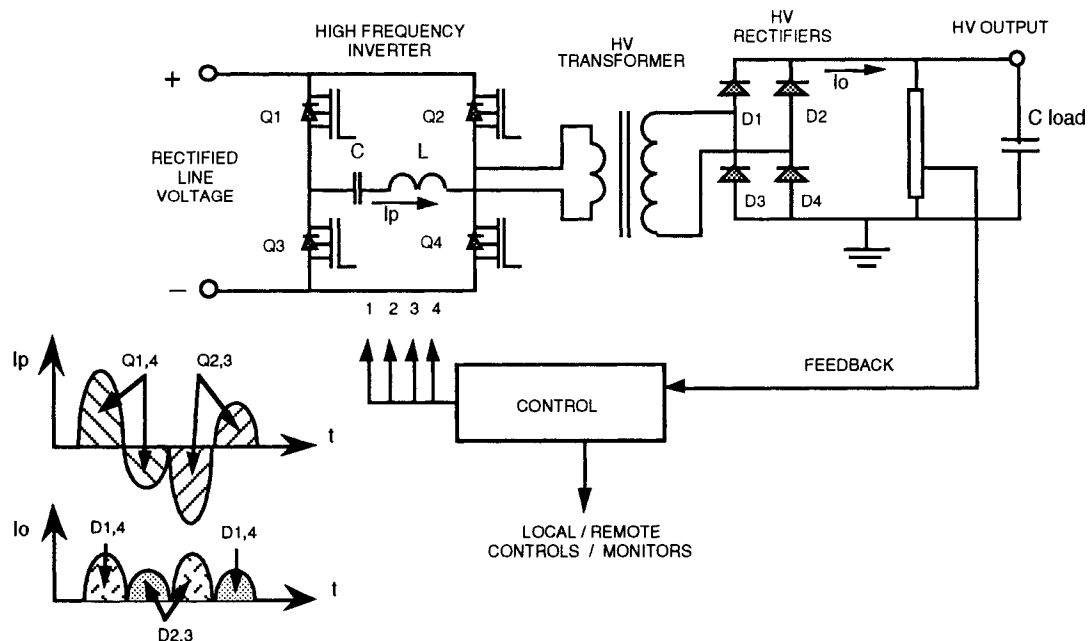

FIGURE 1. CCDS HVPS Basic Circuit Diagram.

resonant configuration as described above, the devices can be made to switch at zero current because of the sine wave property of the current in the LC circuit. As a consequence, the switching transistors have zero switching losses as compared to conventional pulswidth modulated, quasi-square wave converter topologies. The switches have only conduction losses which can easily be calculated from the rms current value and the switch on resistance (for the FET) as:

$$P_{\text{loss}} = (I_{\text{rms}})^2 \times R_{\text{on}} \quad (1)$$

The inverter sine wave current over the entire charging cycle can be accurately predicted if the resonant LC, inverter input voltage and transformer primary voltage are known. The voltage of the output load capacitor reflected back through the primary of the HV transformer appears as a voltage source,  $V_o$ , in series with the inverter circuit. Figure 2 is a simplified circuit diagram of the series resonant converter showing the reflected load voltage,  $V_o$ . Careful analysis of the series resonant equivalent circuit will reveal that the current is a true sine wave only when the output voltage is zero, implying the load is shorted. As the capacitor begins to charge, the current in the forward direction of the bridge switches will increase while the current in the reverse direction will decrease. This is due to the increasing voltage of the load capacitor reflected into the primary circuit,  $V_o$ . By applying Kirckoff's Law to this circuit, the following simple equations can be obtained to describe the current in the forward and reverse directions:

$$I_F = \frac{V_i + V_o}{Z_o} \quad (2)$$

$$I_R = \frac{V_i - V_o}{Z_o} \quad (3)$$

where,

$$Z_o = \sqrt{\frac{L}{C}} \quad (4)$$

The frequency of the resonant current waveform is simply

$$f = \frac{1}{2\pi\sqrt{LC}} \quad (5)$$

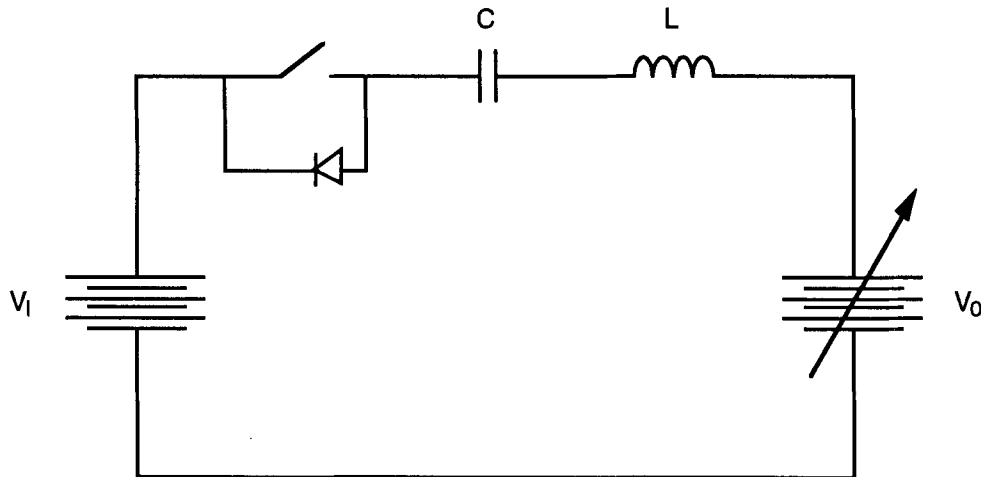

FIGURE 2. Equivalent Series Resonant HVPS Circuit.

Figure 3(a) and Figure 3(b) show the inverter current in the primary of the transformer at the beginning and the end of the charge cycle, respectively. The last few resonant current cycles of the charge cycle resemble spikes of current rather than sinusoids since the input voltage must be greater than the reflected output voltage for current to flow to the load. This mode of operation could be avoided by designing a transformer with a lower primary voltage; however,

that would result in the circulation of more power in the resonant circuit which is never delivered to the load and, consequently, higher conduction losses in the resonant section.

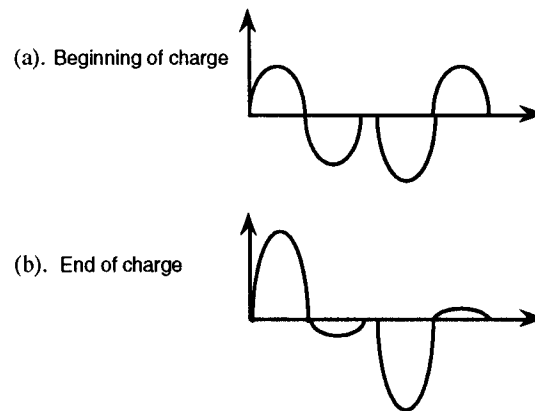

FIGURE 3. Theoretical Series Resonant Current Waveform.

### Control Schemes

Series resonant converters are traditionally controlled with fixed on-time, variable frequency resonant controller chips. This approach guarantees that the inverter switches never turn off during the sinusoidal current pulse, thus assuring zero current switching. However, this also means that fixed quantum of energy will be delivered to the load via the resonant sine wave. For small capacitive loads requiring precise voltage regulation, the fixed quantum of energy may overcharge the capacitor. This is particularly true during the keep-alive portion of the capacitor charging waveform when the power supply is simply supplying current equal to the system leakage current. To avoid this problem, a low loss pulsewidth modulation (PWM) control technique was developed which utilizes MOSFET and IGBT inverter switches.

The CCDS power supply block diagram is shown in Figure 4. The ac input section includes a 3 Ø line circuit breaker, common/differential mode EMI filter, an inrush surge limit circuit, and the 3 Ø line rectifier and filter capacitors. The switching power converter utilizes a series resonant “H” bridge topology which drives the primary of a multisecondary high frequency step-up transformer. Multiple, full-wave bridge, high voltage rectifier circuits produce the rectified high voltage output. The control circuit utilizes a fixed frequency, quasi-pulsed width modulated scheme to drive the power converter. All user controls are buffered and interface with the control circuit directly.

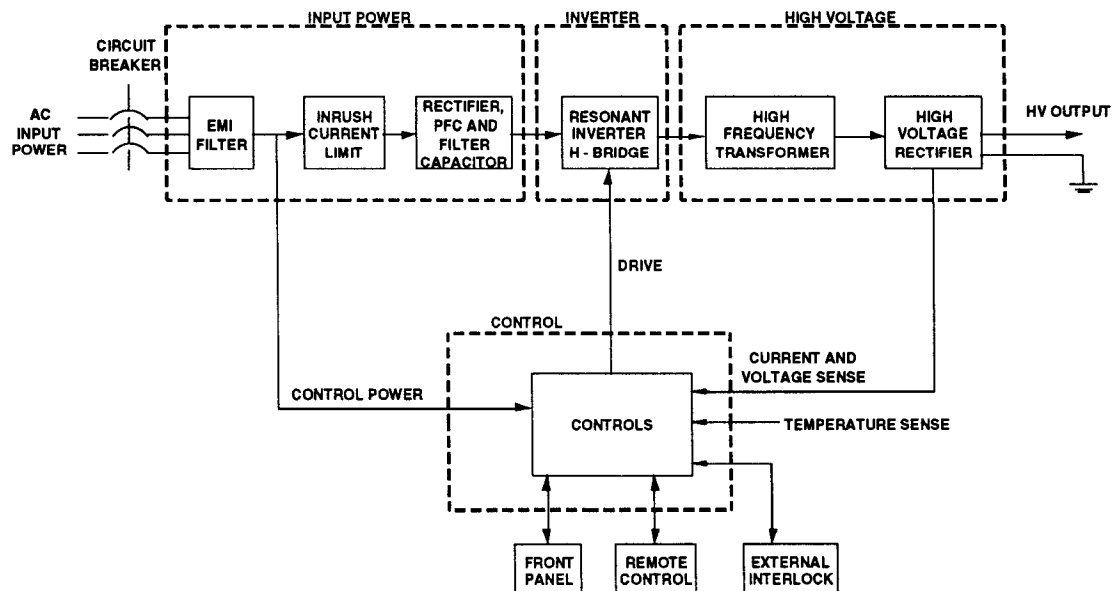

FIGURE 4. CCDS Power Supply Block Diagram.

### **Input EMI Filter**

The 3  $\emptyset$  input EMI filter attenuates both common mode (lines-to-chassis) and differential mode (line-to-line) high frequency noise to assure the power supply does not interfere with any other equipment connected to the main power grid. This includes conducted EMI, i.e., RF noise generated internally by the power supply inverter circuit and externally generated noise which may enter the power supply on the power lines. The filter is composed of a 3  $\emptyset$  balun inductor with "X" (line-to-line) and "Y" (line-to-ground) capacitors placed symmetrically on both sides of the inductor. The filter has a common mode attenuation of better than 40 dB at 1 MHz and above. The filter is designed to readily accommodate modification to meet the leakage requirements of medical applications.

### **Inrush Current Limit and Power Factor Correction**

The inrush current limit circuit prevents high inrush surge currents during the charging of the input capacitors when the circuit breaker is initially turned on. The input capacitors are initially charged through a resistor which limits the inrush charging current to a maximum of 10 A. When the HV ON circuit is activated to start a charging cycle and the inverter turns on, an SCR fires which bypasses the inrush limiting resistor, thus connecting the input capacitors directly to the input rectifiers during inverter operation. As with many commercial power supplies and pieces of laboratory electronic equipment today, the input filter capacitors remain charged as long as the circuit breaker is on and the unit is connected to the power line. This is independent of the position of the control power ON/OFF switch.

For 3  $\emptyset$  inputs, the simplest and most reliable method of achieving power factor correction in accordance with EMC 889/36 (IEC 555 or IEEE 519) is the use of a choke in the input power section. The choke can be placed between the 3  $\emptyset$  rectifier and the input filter capacitors. A choke wound on a conventional steel laminated E-I core is used to achieve a power factor in excess of 0.95.

For applications, such as those considered for space where the power source is a dc bus, the preceding portions of the power supply are omitted. The optimum input voltage from a component availability and power density viewpoint is presently in the range of 1000 Vdc; however, this presents safety concerns. While the power conversion technique is well demonstrated and characterized, the total application drivers must be weighted for their impact on the predefined measurement of success.

### **Series Resonant Inverter**

The power converter utilized in the power supply is a series resonant "H" bridge topology operating in the 50 kHz range. This particular converter topology is ideal for high power, capacitor charging applications since it reflects a high source impedance to the output; consequently, this topology is inherently short circuit proof. The output characteristics of the inverter topology combined with the patented CCDS control topology result in a constant current (linear) charging profile with regulation of  $\pm 0.05\%$  for typical load parameters.

The H-bridge switch elements are comprised of a parallel IGBTs. The characteristics of these devices provide reliable high voltage, high current capability and easy device paralleling and control. While the IGBT has the highest power density in a commercially available transistor today, the CCDS supplies have been designed and tested so MOSFETs can be inserted in the circuit in place of the IGBTs with no additional modification. The result is the ability to procure components which are proven in space applications with no new electrical design efforts. When used as switches in a series resonant configuration as described above, the devices can be made to switch at zero current because of the sine wave property of the current in the LC circuit. As a consequence, the switching transistors have zero switching losses as compared to conventional pulsed width modulated, flyback or quasi-square wave converter topologies. The result is several fold: no switching losses for higher efficiency, no need for fast recovery diodes in the output circuitry, and virtual elimination of the conducted EMI.

### **High Voltage Output Circuitry**

A multiple secondary high voltage transformer is used to transform the inverter voltage to the required output voltage. Multiple high voltage secondary windings are used to reduce the effects of parasitic resonances caused by secondary inductance and self-capacitance and to simplify and standardize the diode assemblies. Each winding is full-wave rectified by a high voltage diode bridge configuration. The rectifier circuits are then connected in series to sum the rectified voltage levels to the final output level.

For units with output voltages  $\geq 10$  kV, the high voltage power transformer and entire high voltage output section is contained in a sealed, dielectric oil filled tank with oil-tight feedthroughs for all input/output lines. By paying careful attention to design stresses and using Maxwell's extensive capacitor impregnation knowledge base, oil insulation will assure maximum long-term reliability of the high voltage section. Maxwell uses typical transformer oil which contains no PCBs.

One of the critical issues on obtaining a high degree of regulation is the high voltage monitor circuit. The voltage divider must be well compensated to allow the voltage monitor signal to accurately follow the actual output voltage waveform. This control is more critical for repetitive loads, such as impulse radar sources, operating in the kilohertz range. Therefore, the voltage probe used has a time response on the order of nanoseconds. This is achieved using a capacitively compensated, resistive voltage divider located in the high voltage section.

### Controls

Pulsed rate modulation (PRM) is conventionally used to control the output current in a resonant power converter, and hence the output voltage regulation in series resonant capacitor charging power supplies. During charging, the power supply essentially runs open loop and the pulse rate is maximum. Once the preset output voltage level is reached, the only output current required from the supply is the keep-alive current. Keep-alive current is required to offset the losses in the circuit. These losses are typically found in either the capacitor's internal parallel impedance or the capacitor's external discharge circuitry. In most applications, keep alive current can be as little as 0.1% of the charging current. PRM control time (or rate) spaces the rectified sinusoidal output current pulses so as to just maintain the desired charge voltage. This results in a low frequency ripple voltage on the capacitor. For applications utilizing small value load capacitors operating at high rep-rates where a high charging current is required, the ripple component may be too large for adequate shot-to-shot regulation. The amount of peak-to-peak ripple or voltage deviation delivered by a PRM controlled supply is given by the following approximation:

$$V = 25 \times \frac{I}{C} , \quad (6)$$

where "C" is the load capacitance in  $\mu\text{F}$ , "I" is the current output of the power supply in amps and 25 is an empirical constant for the combined time in a given configuration. If we assume a load capacitance of 0.1  $\mu\text{F}$  being charged by a 10 kV, 8 kJ/s ( $I_{\text{out}} = 1.6$  A) we get the following peak-to-peak ripple voltage or regulation once final charge voltage is made:

$$V = 25 \times \frac{1.6}{0.1} = 400 \text{ volts} = \frac{400}{10,000} = 4\% (\pm 2\%) \text{ regulation.} \quad (7)$$

For most advanced applications, this percentage of voltage deviation from shot-to-shot is unacceptable. The cause of the high percentage of regulation is inherent in the PRM control scheme. The smallest "quantum" of charge that the supply can deliver during the keep-alive mode is defined by one complete sine wave of current flow during an inverter half-cycle. The amplitude of this is defined by the resonant tank, impedance which is fixed.

One way to deliver a smaller "quantum" of charge is to electrically alter the impedance and frequency of the resonant tank circuit to produce smaller amplitude sine pulses and, hence, small incremental output current pulses. While this technique has been demonstrated in commercial supplies, it requires a more complex control scheme and a minimum of two series resonant inverters.

An alternative approach is to reduce the pulsed width of the inverter sine pulses so that the supply would operate similarly to a flyback or PWM converter; however, doing so during the charging portion of the duty cycle would have the negative consequence of reduced efficiency resulting from higher high switching losses due to non-zero current switching. However, if the duty cycle is made incrementally small such that the inverter current only rises to a small fraction of its resonant amplitude, then the switching losses incurred when the IGBTs switch off would be small and manageable.

The Maxwell/Auburn team combined the two concepts resulting in a patented control scheme which has demonstrated efficiency greater than 92% and shot-to-shot regulation  $\leq \pm 0.05\%$  for typical load parameters of 30 kV, 40 nF, 400 Hz using an 8 kJ/s, 30 kV supply. The supply operates like the PRM technique during charging where the frequency is maximum, and the switching losses are zero due to zero-current switching. Upon reaching  $\approx 98\%$  of the programmed output voltage, the supply begins operating in the PWM mode where the load voltage is regulated by reducing the inverter switch on time. To further enhance the regulation capability, the technique used in the

CCDS supplies allows both the switch on-time and the inverter pulse-rate to vary. Assuming the load capacitance is not excessively lossy, the amount of charge delivered to the load capacitor would now be small enough to maintain the desired high level of regulation and not result in a loss of efficiency or an increase in the component count or complexity of the power conversion circuitry. Figure 5 illustrates the results of this technique compared to conventional PRM.

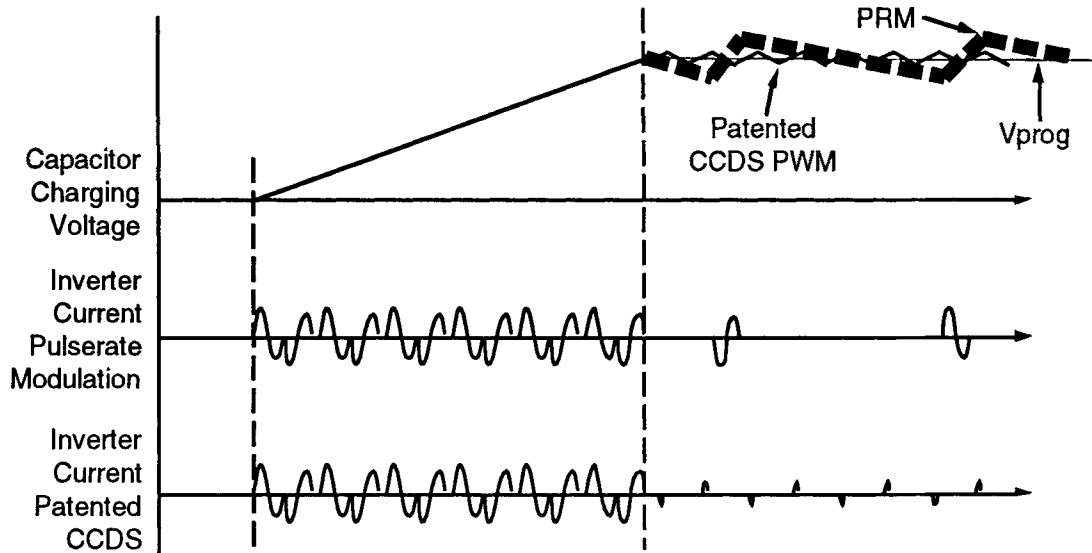

FIGURE 5. Ripple Voltage Regulation.

This patented high regulation control scheme is utilized in Maxwell's CCDS line of capacitor charging switching power supplies. In order to assure that there is not overshoot at the end of the charging cycle, it is necessary to switch into this high regulation control mode during the last fraction of a percent of the charging cycle. Therefore, it is necessary to allow a period of dwell time in the charging cycle as illustrated in Figure 6. This control method has achieved a regulation as high as  $\pm 0.01\%$  in many repetitive applications where such numbers were not previously achievable with commercially available power supplies, and has proven to be a reliable high regulation technique in the field.

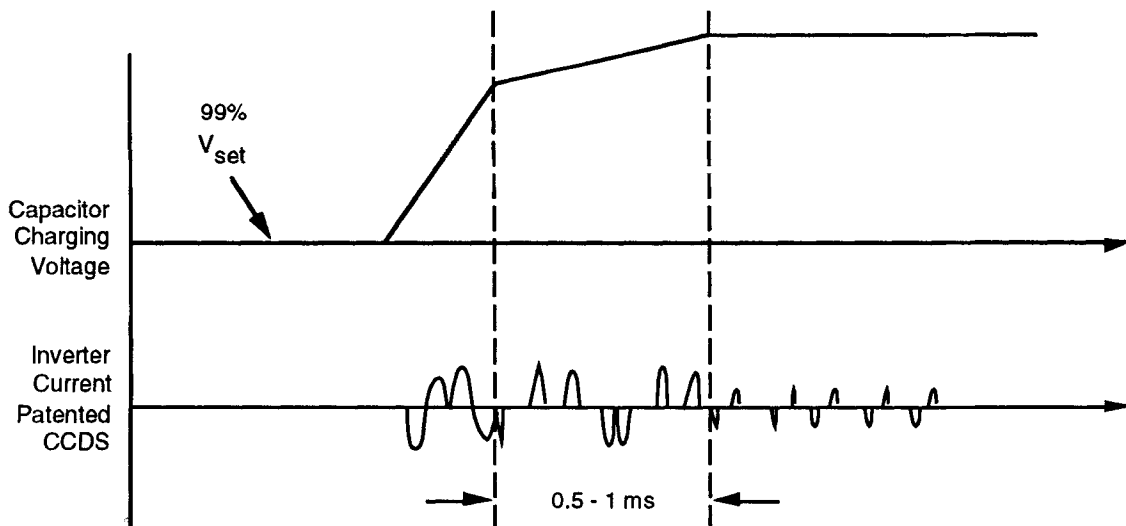

FIGURE 6. Key to Achieving Superior Regulation.



## **A Power Supply for Tomorrow's Laser Applications**

Some of the performance characteristics which are considered when choosing a pulsed industrial laser are output spectrum, high or low power, long or short pulsed length and operating time. By matching the output characteristics of the pulsed train of the laser beam to the physical properties of the work piece while considering the type of work action to be completed, the operation can be efficiently optimized.

For example, when cutting material, initially it is best to use short pulsed widths and high power so that large amounts of energy can be quickly deposited in a small area to efficiently transform the workpiece to a molten state which is not reflective, thus significantly improving the energy absorption of the workpiece material. Once molten, longer, lower energy pulses work well because they allow time for the deposited energy to diffuse into both work pieces which melt and flow together. The low energy pulsed promotes melting and not vaporization.

Carbon dioxide and pulsed ND:YAG solid state lasers provide high peak output power which is necessary for marking of reflective surfaces, thus eliminating the reliance on less environmentally friendly techniques such as ink jet labeling. For marking on glass, plastic or metal, the laser, in the short, intense pulsed mode, ablates minute amounts of surface material before the laser heat can be absorbed by the surrounding material. Its 10.6  $\mu\text{m}$  energy also overcomes the high reflectivity of the metal surface.

The optical output wavelengths of excimer lasers match the absorption regions of various plastics and semiconductors. Twenty to 200 nanosecond pulses at several hundred hertz can produce an average output power of 100 watts or more. Using optics to focus this energy, rapid thermal annealing of large area LCD displays and precision cutting/micro-machining of semiconductors can be performed to produce products presently unavailable at a commercially viable prices.

Today's CO<sub>2</sub>, excimer and solid state lasers are being operated at higher and higher repetition rates in order to achieve greater levels of average output power. One of the challenges this presents to designers of these high power discharge lasers is achieving a uniform and stable discharge. The discharge uniformity and stability are both essential for beam quality and laser efficiency. The quality of the discharge is generally a function of the laser gas mixture, the discharge electrode profiles, the pre-ionization scheme, and the response characteristics of the capacitors and supply power pulsing the laser. In nearly all cases, a fast rising and near constant amplitude voltage pulse is essential for producing a high quality output optical beam. Manufacturers of lasers for marking, cutting, welding and medical treatment have found that use of the CCDS line of power supplies provides quality pulsed power for their lasers. The use of CCDS power supplies, derived from the CCDS experience, allows for a long lived, highly reliable, and consistently operating laser system.

### **Expanding Power Supply Applications**

The CCDS power supply product line has allowed Maxwell to conduct a number of projects which directly grew out of the CCDS technology. For the last four years, Maxwell's dedicated, cross-functional Power Supply Team has provided the customer with solutions to the power supply needs of his pulsed power system. In the last four years, this team has also delivered large numbers of CCDS power supplies to such critical government programs as BEAMLET at Lawrence Livermore National Laboratory (LLNL) where testing in support of the National Ignition Facility (NIF) is presently underway. The BEAMLET capacitor bank is charged with 32 CCDS supplies providing the most cost effective solution to the program's needs. Maxwell recently delivered 50 8 kJ/s units to LLNL for use on the new NOVA BEAMLET laser program.

In 1992 Maxwell's Brobeck division completed installation and commissioning of a complete turnkey 1.2 GeV synchrotron light source system for Louisiana State University (LSU). Maxwell's Power Supply Team supported this project by designing, delivering, and integrating the thyatron modulators required for the four kicker magnets and the one thin septum magnet. Modulators used CCDS power supplies to achieve the rigorous regulation specification in the high EMI environment of the synchrotron (Strickland et al. 1991a and 1991b).

The Power Supply Team also supported various other internal teams where in each case, Maxwell offered superior performance and quality at the lowest price to meet the programs' requirements:

- University of Rochester Team which is currently delivering 120 power conditioning modules to the University of Rochester OMEGA laser program. Each module has a 2 kJ/s CCDS power supply in it.

- SSCL Klystron Modulator Team which delivered the CCL and DTL modulator for the linac. Each used a number of CCDS power supplies operating in parallel for a total of 70 units in the program (Thomas et al. 1993, 1994a, and 1994b).
- DARHT Team who built eight thyratron modulators for the induction linacs for the Dual Axis Radiograph Hydrodynamic Test (DARHT) facility for Los Alamos National Laboratory (LANL). Four of these modulators are the Induction Cell Pulsed Power Supplies (ICPPS). These are pulsed charged Blumlein which drive the linac induction cells. The remaining four modulators are the DARHT trigger systems which provide synchronized, low-jitter, high voltage trigger signals to the ICPPS Blumlein output switches.

In addition to these large programs, Maxwell continues to be an industry leader by using the dual use concept to achieve defense conversion. Leveraging from 25 years of technology development in support of nuclear simulation and threat deterrents, Maxwell is focusing its expertise on commercial applications of pulsed power to solve today's environmental, health, economic and safety issues. The Maxwell Power Supply Team is the first commercial product to reach the market through Maxwell's application of the dual use concept. This team has the capability to manufacture long lifetime, high reliability, capacitor charging power supplies, and now can design and fabricate turnkey power supplies specifically tailored to customer's application requirements. Maxwell is a leader in the production of high voltage capacitor charging power supplies and has provided units to companies throughout the world. Maxwell's custom systems and component manufacturing capabilities allow for the production of components and systems for solving difficult Government and industrial problems (Strickland et. al 1990, Thomas et al. 1992, and Hamelin et al. 1993).

## **SUMMARY**

By applying the technological concepts of government funded development over the past 20 years to technology risk reduction in the development of dual-use products, Maxwell and Auburn have demonstrated the viability and powerful impact the dual-use program can have on an industry and ultimately society as a whole. The collaboration between NASA's Center for Commercial Development of Space at the Auburn University, Space Power Institute and Maxwell Laboratories, has been a win-win-win situation with high levels of success and satisfaction for each organization and the individuals involved.

The development for dual use of power supply technologies through this type of cooperative Government-Industry program provides benefits for all involved parties. A good relationship has evolved between Maxwell and NASA mainly due to the risk sharing aspects of the CCDS development project. While NASA now has access to highly reliable, compact power supplies, a true commercial value has evolved in the form of Maxwell's CCDS product line. In the three to four years since the product introduction, the annual power supply sales have risen to a significant percentage of the corporation's revenues and those sales are expected to double over the next year. Consequently Auburn University and the CCDS group continue to benefit through the royalties they receive for each commercial CCDS power supply unit delivered.

As a result of this demonstration of the dual-use concept to develop a compact, efficient, reliable, high voltage power supply, Maxwell offers the world's most extensive capabilities in pulsed power technologies through its manufacture of turnkey systems, subassemblies and components to create and control bursts of electrical energy. A broad line of energy-storage capacitors has established Maxwell as the leading manufacturer of high quality, high-energy-density capacitors. And now, commercial Maxwell power supplies meet the performance, reliability and cost effectiveness levels established for other Maxwell products while being ready to address future applications for space and defense related customers.

## **Acknowledgments**

We would like to thank Dr. Ray Askew and Dr. Mark Nelms of the Auburn University Space Power Institute, Frank Cathell and Dr. Edmond Chu, Maxwell Laboratories, as well as all of the Power Supply Team members at Maxwell for their dedication in achieving the success of the CCDS power supplies and the NASA CCDS program.

## References

- Cathell, F. J., et al. (1990) "2 kJ/s, 25kV High Frequency Capacitor Charging Power Supply Using Mosfets," in *Proc. 19th Power Modulator Symposium*, CONF-90CH2839-9, San Diego, CA, 531-534.
- Cathell, F. J., et al. (1991) "8 kJ/s High Frequency Capacitor Charging Power Supply Using Parallel Inverters," in *Proc. 8th IEEE Pulsed Power Conference*, CONF-91CH3052-8, San Diego, CA, 245-248.
- Cathell, F. J. and B. E. Strickland (1992) "Bi-Mode High Voltage Resonant Power Supply," *U.S. Patent No. 5,121,314*, 9 June 1992.
- Cathell, F. J., et al. (1993) "High Voltage Capacitor Charging Power Supplies with High Regulation," in *Proc. 27th PCIM Power Conversion Conference*, Irvine, CA, 27:166-180.
- Hamelin, M., et al. (1993) "Hard Rock Fragmentation with Pulsed Power," in *Proc. 9th IEEE International Pulsed Power Conference*, CONF-93CH3350-6, Albuquerque, NM, 1:11-14.
- Strickland, B. E., et al. (1990) "A Solid State Modulator Using Energy Recovery to Deliver 20 kVA to and Inductive Load from a 2.5 kJ/s Power Source," in *Proc. 19th Power Modulator Symposium Conference*, CONF-90CH2839-9, San Diego, CA, 503-506.
- Strickland, B. E., et al. (1991a) "Fast Power Supplies for the Kicker and Thin Septum Magnets in a 1.2 GeV Synchrotron Radiation Source," in *Conference Record of the 1991 IEEE Particle Accelerator Conference*, CONF-91CH3038-7, San Francisco, CA, 5:3171-3173.
- Strickland, B. E., et al. (1991b) "Thyratron Switched Pulsed Modulators For the Kicker and Thin Septum Magnets in a 1.2 GeV Synchrotron Radiation Source," in *Proc. 8th IEEE Pulsed Power Conference*, CONF-91CH3052-8, San Diego, CA, 953-956.
- Thomas, B. L., et al. (1992) "A 6 kA, 100 Hz SCR Switched Modulator for Driving an Inductive Load," in *Proc. 20th Power Modulator Symposium*, CONF-92CH3180-7, Myrtle Beach, SC, 285-288.
- Thomas, B. L., et al. (1993) "Thyratron Modulators for the Superconducting Supercollider Drift Tube and Coupled Cavity Linacs," in *Proc. 9th IEEE International Pulsed Power Conference*, CONF-93CH3350-6, Albuquerque, NM, 2:873-875.
- Thomas, B. L., et al. (1994a) "Computer Control of High Power Klystron Modulators," to be published in *Proc. 22nd Power Modulator Symposium*, Costa Mesa, CA.
- Thomas, B. L., et al. (1994b) "Testing of the SSC DTL and CCL Klystron Modulators," to be published in *Proc. 22nd Power Modulator Symposium*, Costa Mesa, CA.