

72850-502E Static Breakdown Voltage

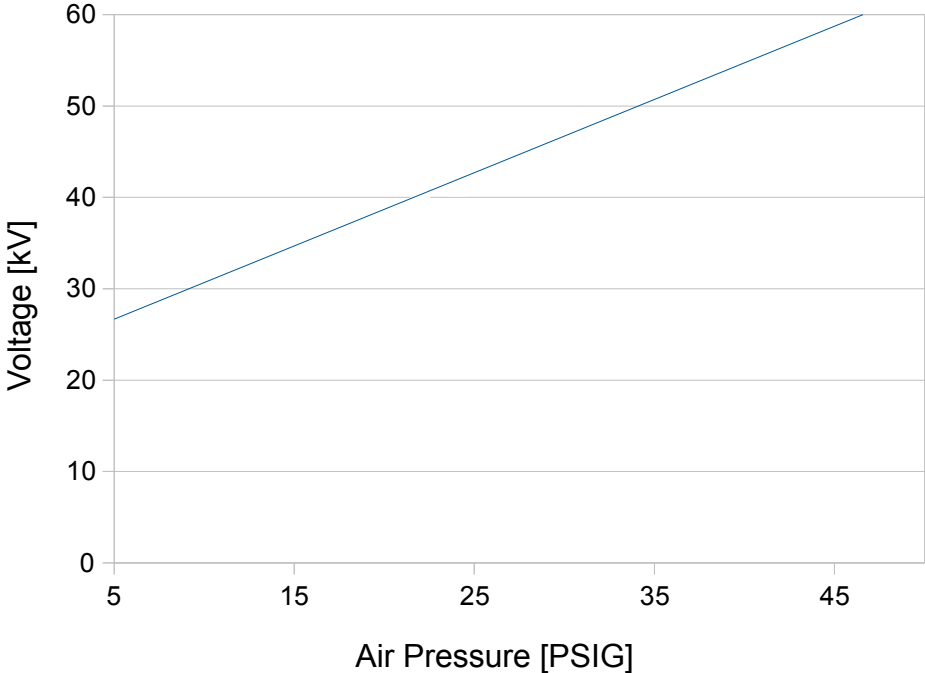

Operating voltage should be approximately 80% of the static-breakdown level. Connect as model 40280.

TYPICAL CIRCUIT ARRANGEMENT FOR MAXWELL SPARK GAPS

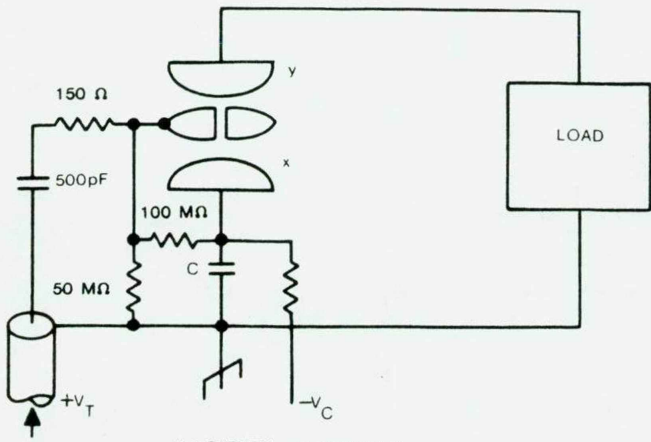

MODEL #40044

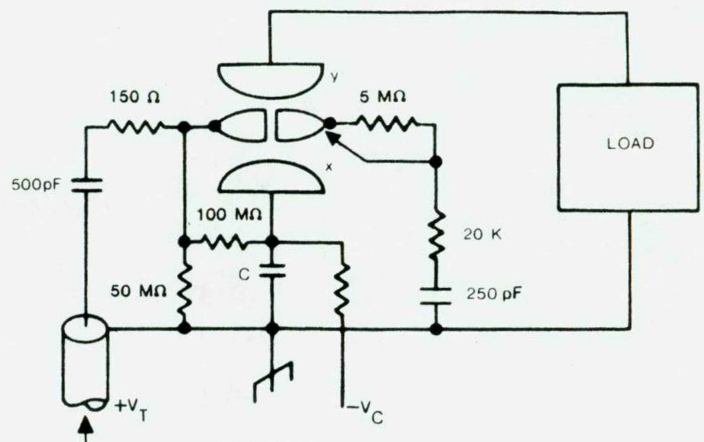

MODEL #40184, 40280

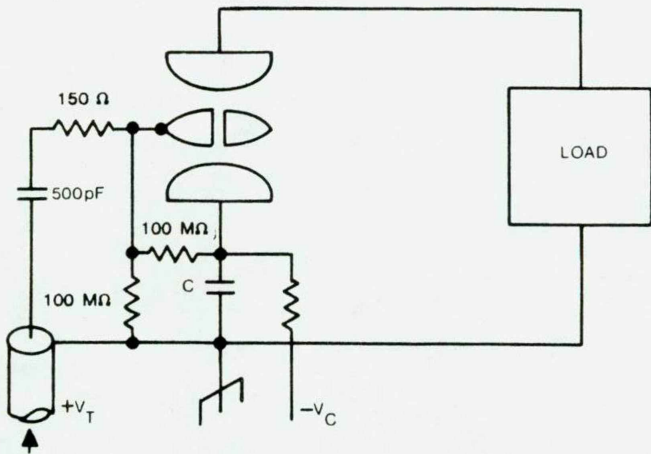

MODEL #40065, 40169, 40265

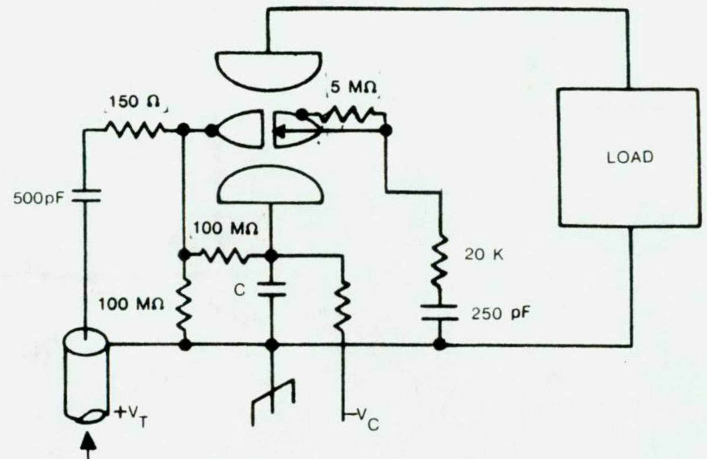

MODEL #40144

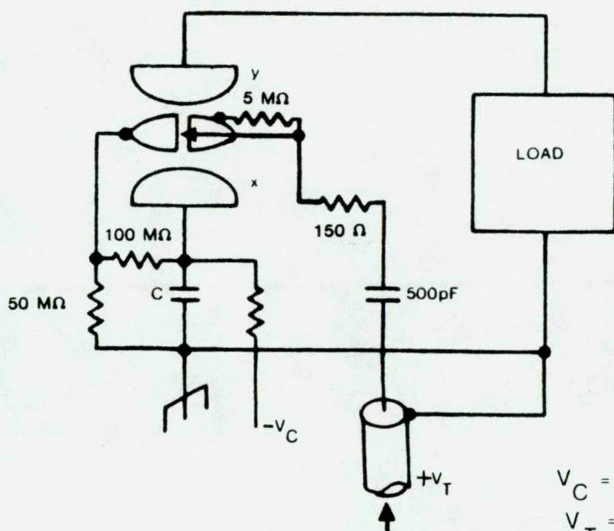

MODEL #40263

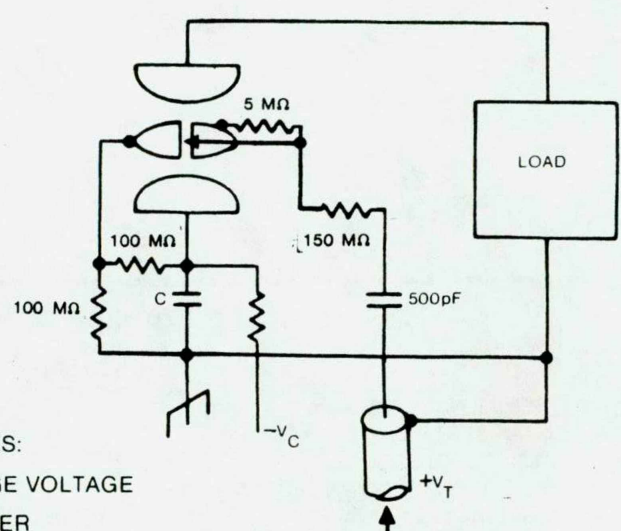

MODEL #40264, 40264-R

NOTES:

$V_C$  = CHARGE VOLTAGE

$V_T$  = TRIGGER

MODELS: 40044, 40184, 40263, AND 40280 CENTER ELECTRODES ARE BIASED AT  $1/3 V_C$ . ALL OTHER MODELS CENTER ELECTRODES ARE BIASED AT  $1/2 V_C$ .