

REVISIONS				
REV	ZONE	DESCRIPTION	CHANGED BY	APPROVED

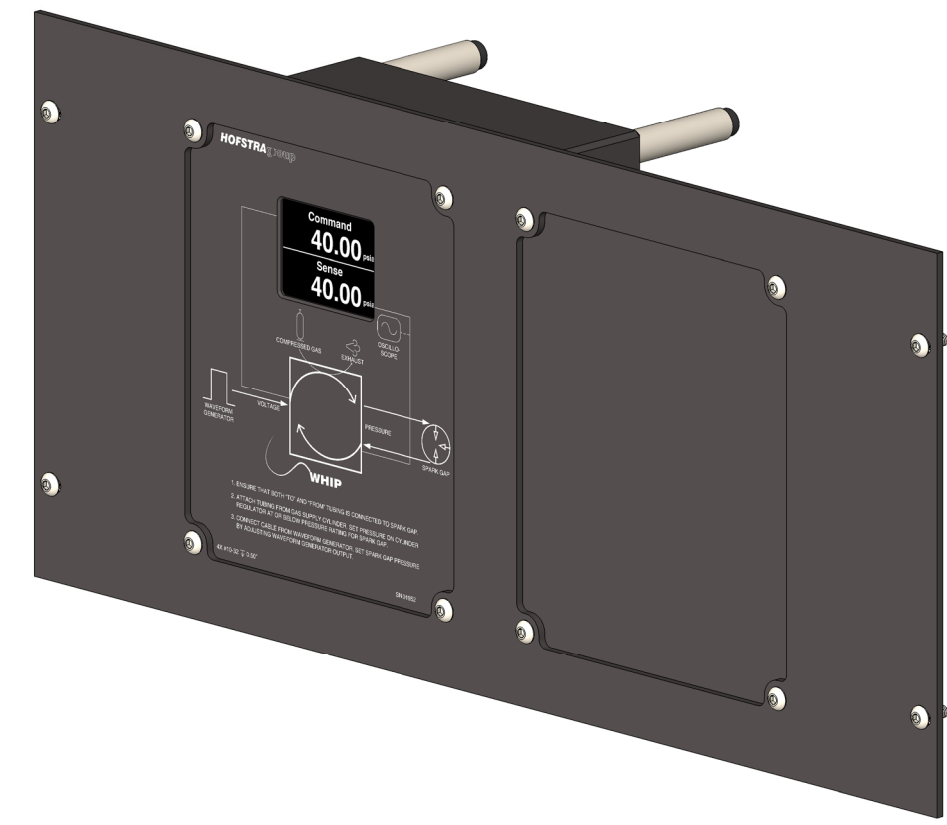
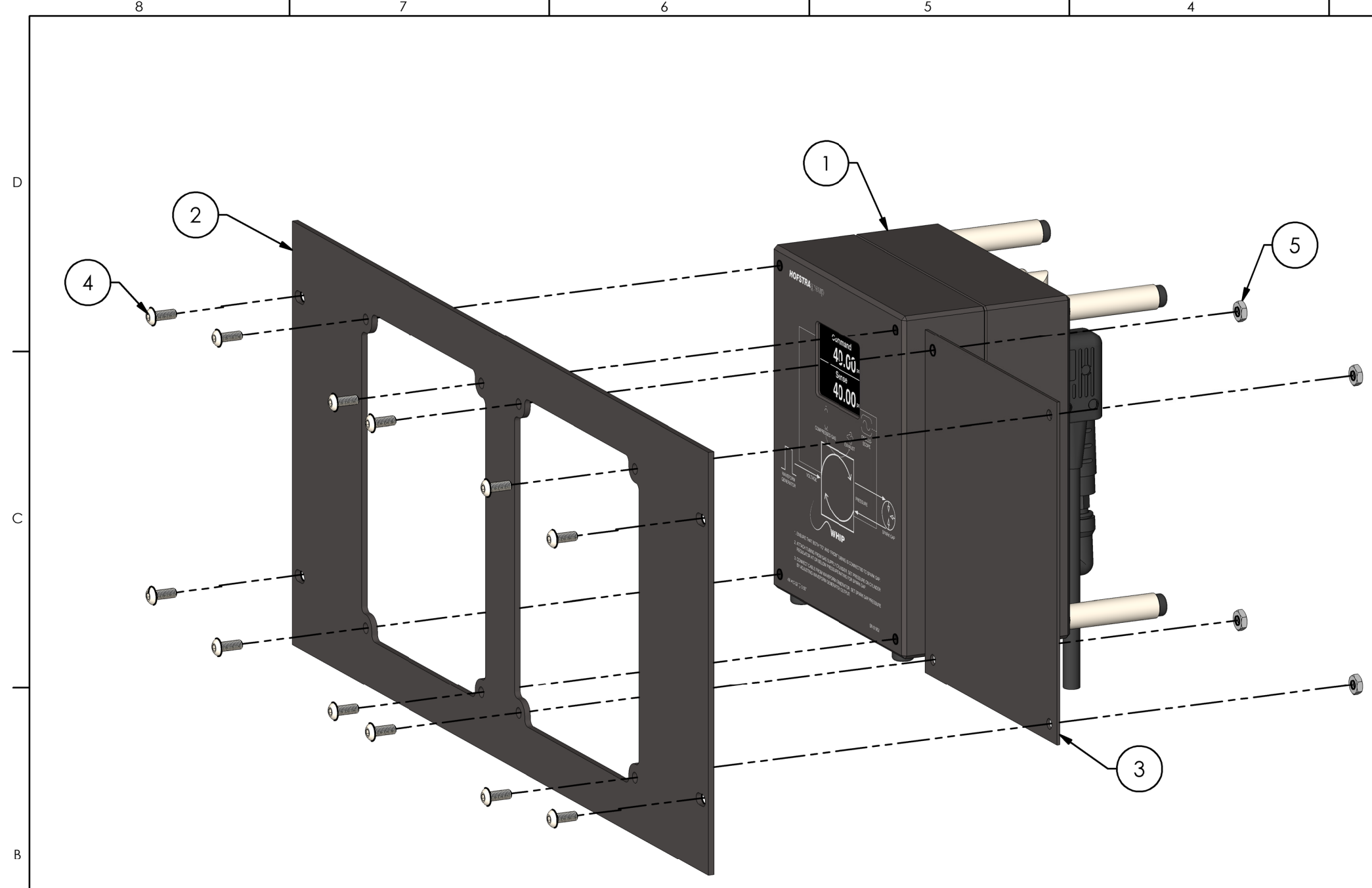

ITEM	QTY	PART NUMBER	DESCRIPTION	MATERIAL
5	4	MCMaster 91841A195	#10-32 HEX NUT, 3/8 HEX X .125 T	18-8 STAINLESS STEEL
4	12	MCMaster 92949A265	BHCS #10-32 X .500 LONG	18-8 STAINLESS STEEL
3	1	HOFSTRA GROUP HG-5466	FRONT PANEL BLANK	6061-T6 ALUMINUM
2	1	HOFSTRA GROUP HG-5465	19\"/>	

**PARTS LIST / BILL OF MATERIALS**

UNLESS OTHERWISE SPECIFIED, DIMENSIONS ARE IN INCHES TOLERANCES ARE: .X = ± .030 .XX = ± .010 .XXX = ± .005 ANGULAR = ± 1° MACHINED FINISH = 63/		<b>INITIAL RELEASE APPROVALS</b>			<b>Hofstra Group, Ltd. Co.</b>	
		DESIGNED	PEER HOFSTRA	HG	MM/DD/YY	PROJECT 4290
NONE		DRAWN	DANNY GALLANT	GI	06/02/18	FRONT PANEL ASSEMBLY
		CHECKED	PEER HOFSTRA	HG	06/02/18	
		APPROVED	PEER HOFSTRA	HG	06/02/18	
DRAWING NUMBER		REV		DRAWING NUMBER		
HG-5457		A		HG-5457		
SCALE: NONE		DO NOT SCALE DRAWING		SHEET 1 OF 1		

900 FOR TECHNICAL QUESTIONS, CONTACT:  
 PEER HOFSTRA, (505) 913-9916  
 500 THOROUGHLY CLEAN PARTS TO REMOVE ALL OIL,  
 GREASE, DIRT, CHIPS, ETC.  
 104 ABBREVIATIONS PER ASME Y14.38-2007.  
**NOTES** (UNLESS OTHERWISE SPECIFIED)

MCMaster-CARR  
 WWW.MCMaster.COM  
 VENDOR LIST