

REVISIONS					
REV	ZONE	DESCRIPTION	CHANGED BY	APPROVED	MM/DD/YY

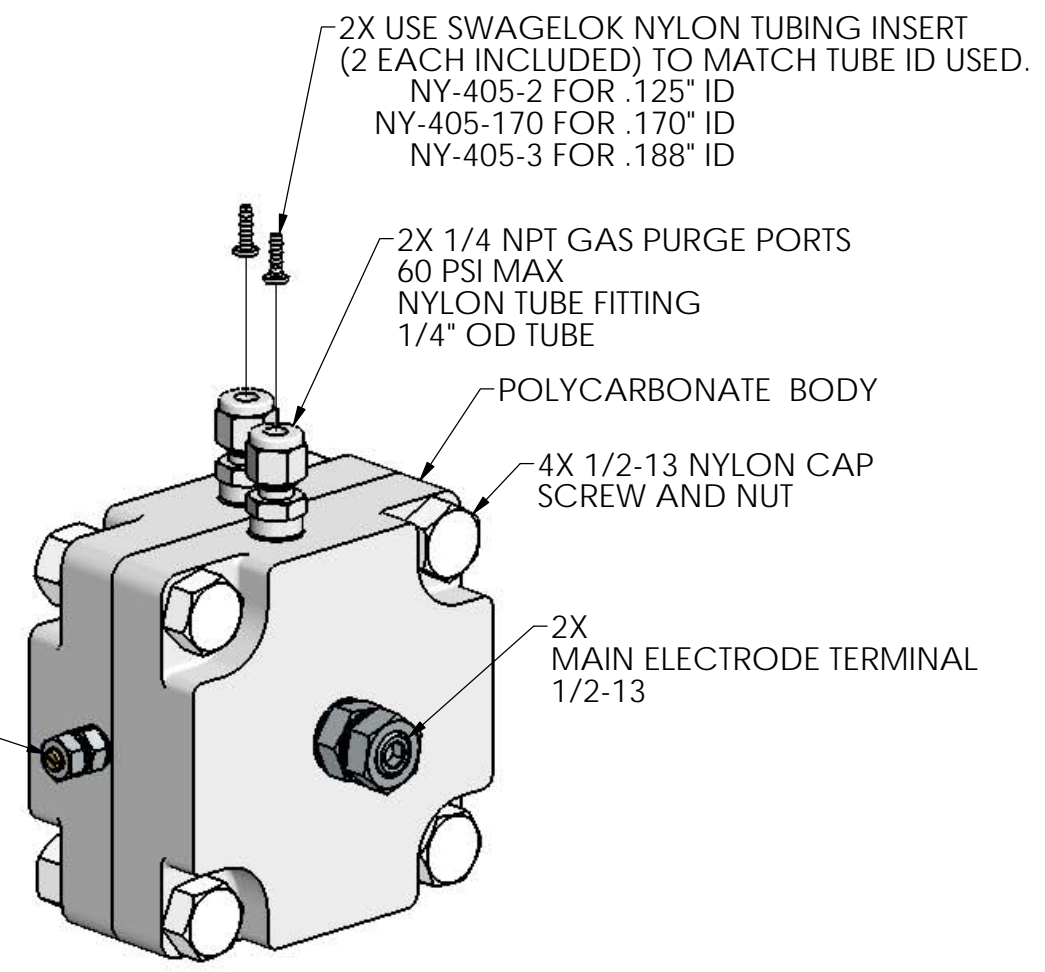
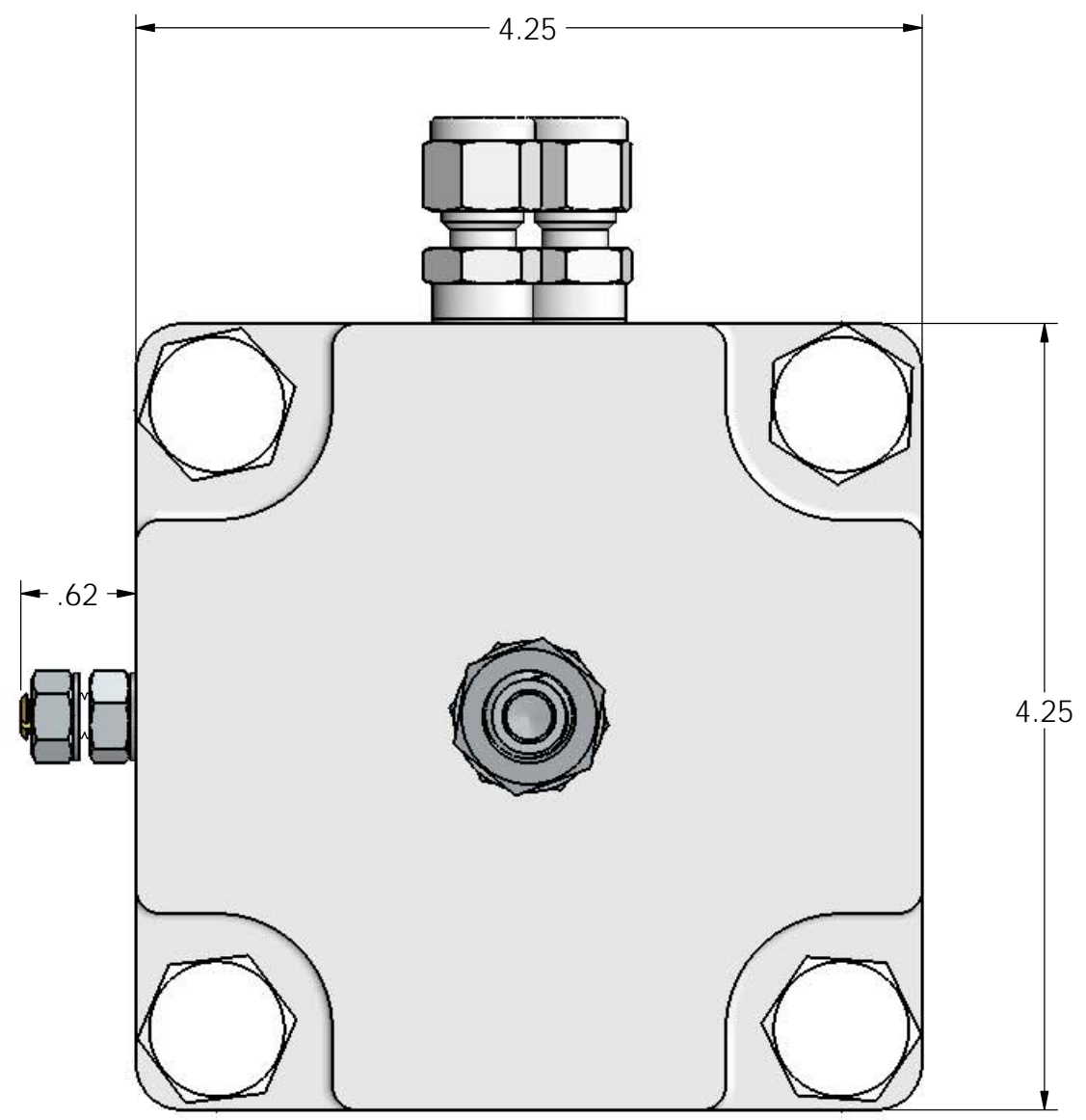
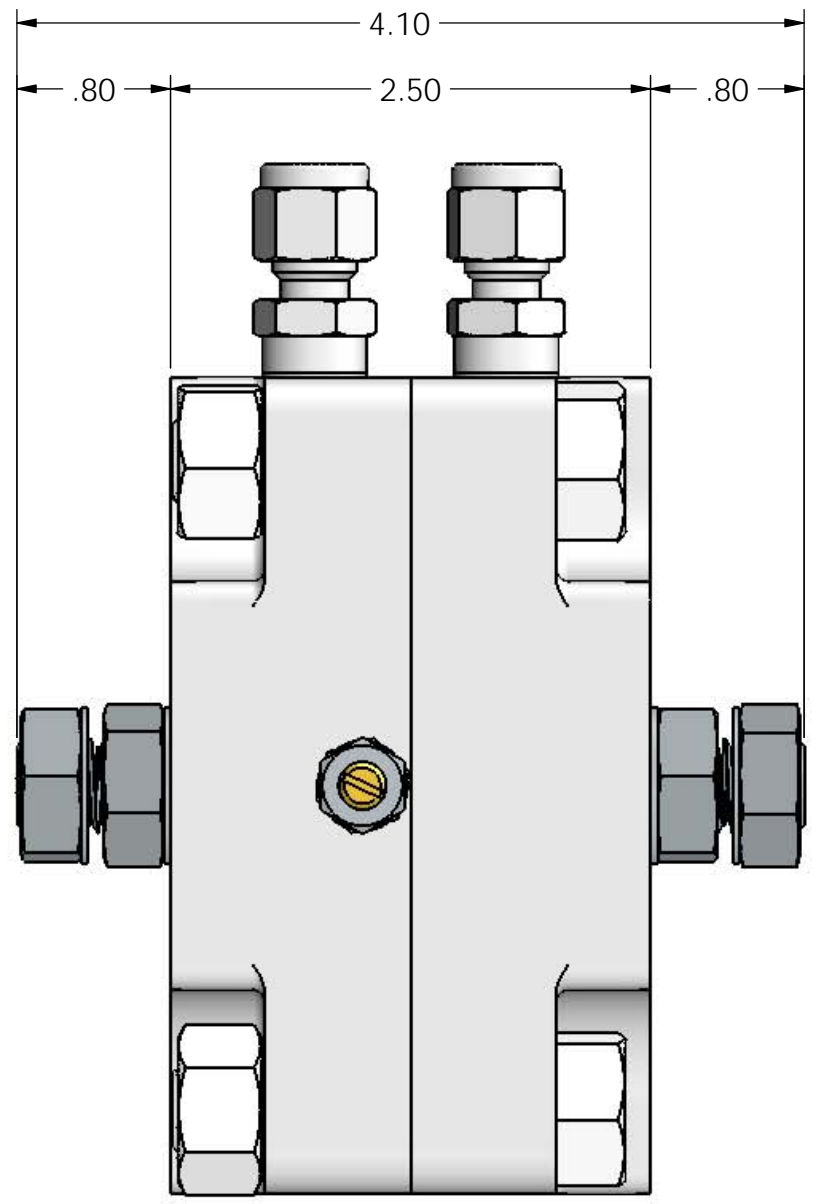

ALL DIMENSIONS ARE NOMINAL FOR REFERENCE ONLY

UNLESS OTHERWISE SPECIFIED, DIMENSIONS ARE IN INCHES. TOLERANCES ARE: .X = ± .XX = ± .XXX = ± ANGULAR = ± ° MACHINED FINISH = ✓	INITIAL RELEASE APPROVALS			MM/DD/YY	Hofstra Group, Ltd. Co. PROJECT 4216/3114 HIGH VOLTAGE TRIGGERED SPARK GAP SWITCH SPECIFICATIONS DRAWING DRAWING NUMBER HG-5324 REV C
	DESIGNED	DANNY GALLANT	GI	06/22/16	
	APPROVED	PEER HOFSTRA	HG	06/22/16	
NONE					SIZE B SCALE: NONE DO NOT SCALE DRAWING SHEET 1 OF 1

A

B

C

D