

# ORCA-R<sup>2</sup>

Digital CCD camera C10600-10B



#### Fast readout speed

Max 115.1 frames/s  
(with binning, sub-array)  
16.2 frames/s (full resolution)

#### Deeper cooling temperature

- 40 °C (Water cooled)

#### Lower noise (Dark current / Readout noise)

6 electrons (rms)

#### Selectable A/D converter

12 bit / 16 bit

## Wide range and high QE from visible to NIR, with low noise and high resolution

ORCA-R2 is a high resolution cooled digital CCD camera with great sensitivity from UV to NIR.

Thanks to the famous ER-150 CCD chip with a peak QE over 70 % and significant noise reduction from advanced cooling and circuit design a dynamic range of up to 6000:1 is possible in this interline transfer camera. Combined with the Hamamatsu proprietary hermetic vacuum-sealed chamber technology this camera offers long term maintenance free operation for the most demanding applications and environments.

Additional software selectable features make the camera suitable for almost any scientific application. Simply select your choice of water or air cooling, 12 bit or 16 bit digitizer, high light or low light mode, 14 MHz or 28 MHz readout speed and you have the right camera for life science microscopy, semiconductor imaging, X-ray scintillator readout or industrial imaging.

Regardless of your application or mode of operation, the universal IEEE1394b interface will provide fast, easy, reliable operation.

#### APPLICATIONS

- Fluorescence microscopy
- Live cells expressing GFP
- Red to NIR fluorescence application
- Ratio imaging
- Fluorescence in situ hybridization (FISH)
- IR-DIC and fluorescence imaging
- Cell, tissue, pathology
- Time lapse fluorescence imaging
- TIRF microscopy, real-time confocal microscopy
- Failure analysis
- Semiconductor inspection
- X-ray scintillator readout

**HAMAMATSU**

PHOTON IS OUR BUSINESS

## FEATURES

### High sensitivity

#### ● High quantum efficiency of over 70 %

This camera provides QE of over 70 %. This camera has high sensitivity at visible to near infrared region.

#### ● Dual light mode

This camera has dual light mode (low light mode and high light mode) for various imaging situations. Low light mode provides high sensitivity for broad wavelength from visible to near infrared.

#### ● UV sensitivity

This camera has sensitivity in UV wavelength over 300 nm.

#### ■ Spectral Response

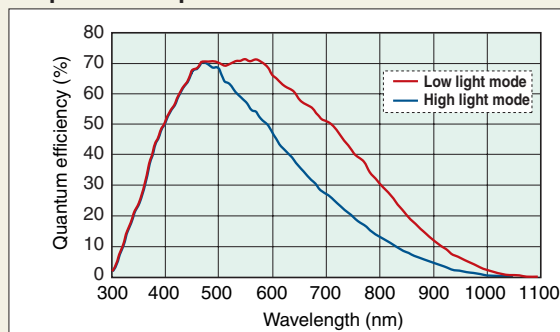

★ This sample is typical of the CCD characteristics, not guaranteed.

### Fast readout / low noise

#### ● Dual scan mode

This camera has selectable normal and scan modes for optimal image acquisition.

#### ● Fast readout speed of 16.2 frames/s (full resolution)

This camera provides a fast readout speed of 16.2 frames / sec at full resolution.

#### ● Fastest readout speed of 115.1 frames/s (with binning, sub-array)

The fastest frame rate is 115.1 frames/s using fast scan mode with 8x8 binning and 8 sub-array.

#### ● Low readout noise (Optimized circuit design)

This camera has a dual optimized circuit design for normal and fast scan respectively, in order to minimize readout noise. Values as low as 6 electrons (rms) at normal scan and 10 electrons (rms) at fast scan.

### High performance cooling

#### ● Dual cooling

Dark current is significantly reduced by cooling the CCD with a peltier element (Thermo-electric cooling device). Air or water-cooling is selectable for optimal image acquisition.

#### ● High cooling performance down to -40 °C (Water cooling)

This camera has high cooling performance down to -40 °C in water-cooled mode with +20 °C circulating water. This camera provides significantly low dark current of 0.0005 electrons/pixel/s.

#### ● Superior air cooling

This camera provides high cooling performance down to -35 °C even in air cooling mode. The maintenance-free hermetic vacuum sealed chamber, new peltier element and optimal heat radiation design contribute to this high cooling performance. Furthermore, the cooling fan can be stopped temporarily to avoid minimal vibrations or electromagnetic noise during image acquisition.

#### ■ Temperature stability

Water-cooling: high temperature stability +/- 0.05 °C at cooling temperature -40 °C (with water temperature of +20 °C)

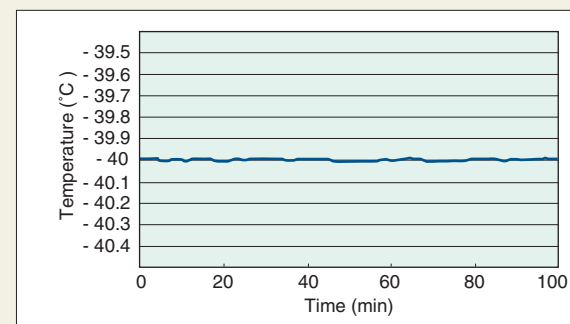

### Contrast enhancement

#### ● Analog contrast enhancement

Analog gain and analog offset features are implemented. By combining these two features, it enables to enhance analog signal to obtain higher contrast image before converting to digital signal.

#### ■ Image comparison

● Before contrast enhancement

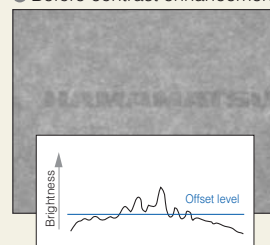

Set offset level to image signal

● After contrast enhancement

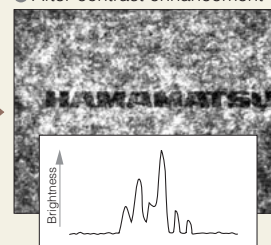

Enhance signal level above the offset level

## High dynamic range

### Standard dynamic range - 3000:1

Standard dynamic range is 3000:1 at full spatial resolution in normal scan mode. This is higher than most comparable cameras.

### High dynamic range mode - 6000:1

This mode offers an increased full well capacity of 36 000 electrons when binning. This mode can only be used in normal scan mode.

### Exposure time and output

Example of output variation by time under constant incident light. Output unit is indicated in electrons.

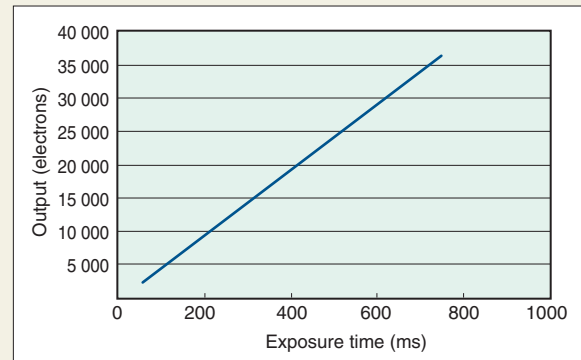

## Special features for scientific imaging

### Dual A/D converter

This camera has both 12 bit and 16 bit digitizer. In applications when a small quantization error is required, the 16 bit digitization is the recommended choice.

### IEEE1394b interface

ORCA-R2 utilizes the IEEE1394b interface for fast data transfer. This interface can easily accommodate the 16.2 Hz frame rate in fast scan mode.

### Synchronous output

#### Exposure output

Pulse output with the same timing as exposure timing.

#### Programmable timing out

A timing delay and the pulse length are programmed by command and synchronized to the start of exposure. This feature can be used as simple delay unit or pulse generator.

#### Trigger ready out

During exposure a "ready" signal is output to indicate whether the next trigger pulse can be accepted or not.

### External trigger mode

#### Edge trigger

Camera starts exposure upon input of a trigger pulse (positive or negative signal edge). The exposure time is set in the application software. When another trigger signal is input during the exposure time, the camera disregards the trigger signal until the exposure automatically ends. Readout begins at the end of exposure.

#### Level trigger

Camera starts exposure upon input of trigger pulse (positive or negative signal edge) and continues until the end of the trigger pulse. Readout begins at the end of exposure.

#### Synchronous readout trigger

Camera starts exposure upon input of a trigger pulse (positive or negative signal edge) and continues until the correct number of trigger pulses (signal edges) have been received. The number of pulses is set in software. This mode is preferred because it allows the longest externally synchronized exposure time with the minimum dead time since the camera can exposure and readout at the same time. It also provides full synchronization of the camera with trigger pulses that have uncertain timing or jitter.

#### Start Trigger

Camera starts exposure upon input of a trigger pulse (positive or negative signal edge) and is immediately switched to internal synchronization. This feature provides consecutive image acquisition from a single trigger pulse and the fastest frame rates due to the internal synchronization that allows the camera to exposure and readout at the same time.

## SYSTEM CONFIGURATION

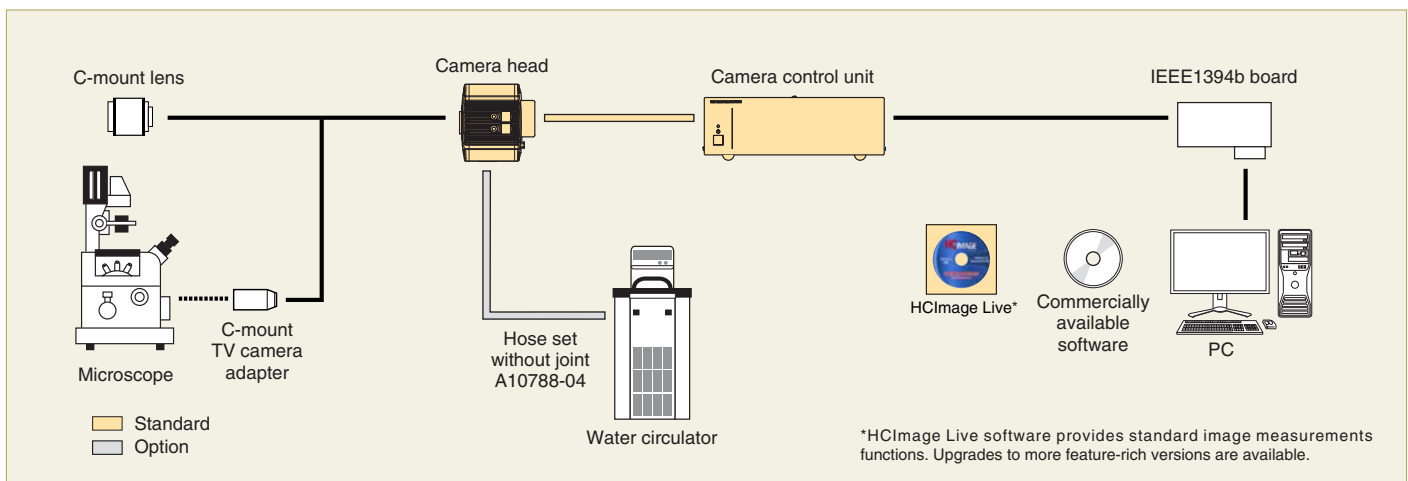

Please contact your local Hamamatsu representative or distributor regarding actual configuration.

## SPECIFICATIONS

Product name	<b>ORCA-R2 Digital CCD camera</b>	
Type number	<b>C10600-10B</b>	
Camera head type	Hermetic vacuum-sealed head	
Dual cooling	Air cooling / water cooling	
Imaging device	ER-150 progressive scan interline CCD	
Effective number of pixels	1344 (H) × 1024 (V)	
Cell size	6.45 μm (H) × 6.45 μm (V)	
Effective area	8.67 mm (H) × 6.60 mm (V)	
Dual scan mode	Normal scan / Fast scan	
Pixel clock rate	Normal scan	14.00 MHz/pixel
	Fast scan	28.00 MHz/pixel
Readout noise (rms) typ.	Normal scan	6 electrons
	Fast scan	10 electrons
Full well capacity typ.	High dynamic range mode* OFF	18 000 electrons
	ON	36 000 electrons
Dynamic range typ.	3000 : 1 (at Normal scan / 1X1)	
Cooling method / temperature	Forced-air cooled	- 35 °C
	Water cooled	- 40 °C (Water temperature : +20 °C)
Dark current	0.0005 electrons/pixel/s (at - 40 °C)	
Dual A/D converter	12 bit or 16 bit	
Exposure time	10 μs to 4200 s	
Binning	2 × 2, 4 × 4, 8 × 8	
Sub-array	Yes	
Dual light mode	Low light mode / High light mode	
High dynamic range mode*	Yes	
Analog gain feature	Yes (10 times max.)	
Analog offset feature	Yes	
External trigger mode	Edge trigger, Level trigger, Synchronous readout trigger, Start trigger	
Trigger output	Integ output, Programmable timing output, Trigger ready output	
Lens mount	C-mount	
Interface	IEEE1394b-2002	
External control	IIDC 1394-Based Digital Camera Specification Ver.1.31	
Power requirements	AC 100 V to AC 240 V, 50 Hz / 60 Hz	
Power consumption	Approx. 60 VA	
Ambient storage temperature	- 10 °C to + 50 °C	
Ambient operating temperature	0 °C to + 40 °C	
Ambient operating humidity	70 % max. (with no condensation)	

\* High dynamic range mode is only available in normal scan mode with binning.

## ● Fastest readout speed

[ Normal scan ] (Unit : frame/s)

binning	Sub-array (Effective pixel of vertical direction)							
	1024	512	256	128	64	32	16	8
1 × 1	8.5	15.6	26.7	41.4	57.2	70.6	80.0	85.7
2 × 2	15.6	26.7	41.4	57.2	70.6	80.0	85.7	88.8
4 × 4	26.7	41.4	57.2	70.6	80.0	85.7	88.8	90.5
8 × 8	40.6	56.3	69.8	79.2	85.0	88.2	89.9	90.8

[ Fast scan ] (Unit : frame/s)

binning	Sub-array (Effective pixel of vertical direction)							
	1024	512	256	128	64	32	16	8
1 × 1	16.2	28.4	45.7	65.6	83.9	97.5	106.2	111.1
2 × 2	28.4	45.7	65.6	83.9	97.5	106.2	111.1	113.7
4 × 4	45.7	65.6	83.9	97.5	106.2	111.1	113.7	115.0
8 × 8	64.3	82.7	96.5	105.3	110.3	113.0	114.4	115.1

## DIMENSIONAL OUTLINES

(Unit : mm)

### ■ Camera head (Approx. 1.1 kg)

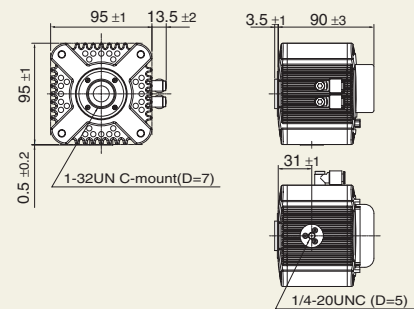

### ■ Camera control unit (Approx. 2.8 kg)

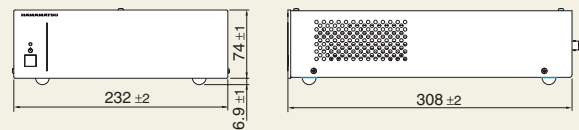

ORCA is registered trademark of Hamamatsu Photonics K.K. (France, Germany, Japan, U.K., U.S.A.)

HCIMAGE is registered trademark of PHOTONICS MANAGEMENT CORP. (Australia, China, EU, Japan, Norway, Singapore, Switzerland, U.S.A.)

Product and software package names noted in this documentation are trademarks or registered trademarks of their respective manufacturers.

● Subject to local technical requirements and regulations, availability of products included in this promotional material may vary. Please consult your local sales representative.

● Information furnished by HAMAMATSU is believed to be reliable. However, no responsibility is assumed for possible inaccuracies or omissions.

Specifications and external appearance are subject to change without notice.

© 2015 Hamamatsu Photonics K.K.

## HAMAMATSU PHOTONICS K.K. [www.hamamatsu.com](http://www.hamamatsu.com)

### HAMAMATSU PHOTONICS K.K., Systems Division

812 Joko-cho, Higashi-ku, Hamamatsu City, 431-3196, Japan, Telephone: (81)53-431-0124, Fax: (81)53-435-1574, E-mail: [export@sys.hpk.co.jp](mailto:export@sys.hpk.co.jp)

U.S.A.: Hamamatsu Corporation, 360 Foothill Road, Bridgewater, N.J 08807, U.S.A., Telephone: (1)908-231-0960, Fax: (1)908-231-1218 E-mail: [usa@hamamatsu.com](mailto:usa@hamamatsu.com)

Germany: Hamamatsu Photonics Deutschland GmbH: Arzbergerstr. 10, D-82211 Herrsching am Ammersee, Germany, Telephone: (49)8152-375-0, Fax: (49)8152-265-8 E-mail: [info@hamamatsu.de](mailto:info@hamamatsu.de)

France: Hamamatsu Photonics France S.A.R.L.: 19, Rue du Saule Trapu, Parc du Moulin de Massy, 91882 Massy Cedex, France, Telephone: (33)1 69 53 71 00, Fax: (33)1 69 53 71 10 E-mail: [infos@hamamatsu.fr](mailto:infos@hamamatsu.fr)

United Kingdom: Hamamatsu Photonics UK Limited: 2 Howard Court, 10 Tewin Road, Welwyn Garden City, Hertfordshire AL7 1BW, UK, Telephone: (44)1707-294888, Fax: (44)1707-325777 E-mail: [info@hamamatsu.co.uk](mailto:info@hamamatsu.co.uk)

North Europe: Hamamatsu Photonics Norden AB: Torshamnsgatan 35 16440 Kista, Sweden, Telephone: (46)8-509-031-00, Fax: (46)8-509-031-01 E-mail: [info@hamamatsu.se](mailto:info@hamamatsu.se)

Italy: Hamamatsu Photonics Italia S.r.l.: Strada della Moia, 1 int. 6 20020 Arese (Milano), Italy, Telephone: (39)02-93581733, Fax: (39)02-93581741 E-mail: [info@hamamatsu.it](mailto:info@hamamatsu.it)

China: Hamamatsu Photonics (China) Co., Ltd.: B1201 Jiaming Center, No.27 Dongsanhuan Beilu, Chaoyang District, Beijing 100020, China, Telephone: (86)10-6586-6006, Fax: (86)10-6586-2866 E-mail: [hpc@hamamatsu.com.cn](mailto:hpc@hamamatsu.com.cn)

Cat. No. SCAS0054E05  
MAR/2015 HPK  
Created in Japan